



P_{100} is the continuous (100% ED) excitation power per coil at which the coil attains temperature T_{max} with the part mounted to a massive heatsink at 20°C with both coils energised at equal power.

P_{100} 5 W

Total Mass 400 g

T_{max} 130 °C

Coil Mass 40 g

Model No.	Resistance R_{20}	Inductance	Torque Constant	Deflection Constant	Current I_{100}
VMXY80-400-200	3.5 Ω	0.2 mH	0.020 Nm/A	1.31 °/A	1.0 A
VMXY80-400-250	2.6 Ω	0.3 mH	0.016 Nm/A	1.06 °/A	1.2 A

Max 'ON' time		
100% ED	∞	0.02 Nm
50% ED	22 s	0.03 Nm
25% ED	9 s	0.04 Nm
10% ED	3 s	0.06 Nm

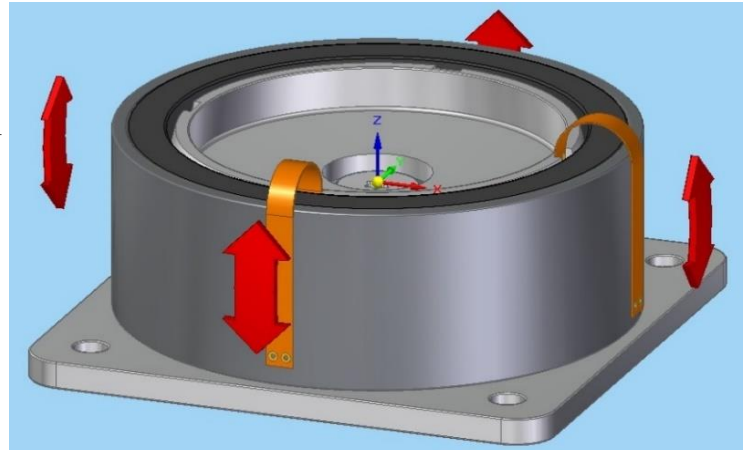
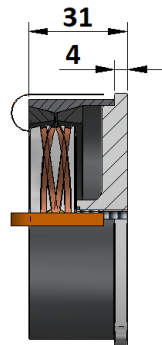
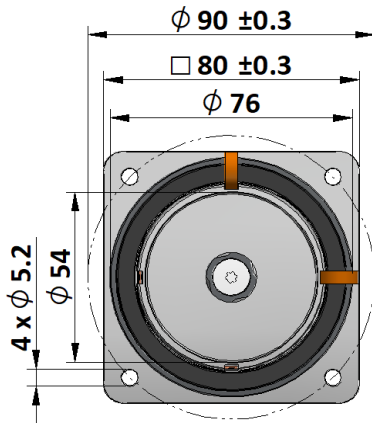

The VMXY80 voice coil actuator provides rotational deflection about 2 axes, intended for steering of optical beams or other application.

The moving element is supported on a steel flexure for frictionless movement.

The device has two coil pairs which develop torque about either the X or Y axis when energised. Torque is proportional to the excitation current, and results in a deflection proportional to the excitation current.

The design of the device is scalable - smaller or larger devices with similar construction are possible subject to quantities being economically viable, however it should be noted that the 80mm diameter device is approaching the upper size limit for which radial magnets are available. Larger devices can be realised using segmented magnets, and may be more readily manufactured with square format.

The Part Number has the format VMXY80-XXX-YYY where the numbers XXX represent thickness of the supporting flexure in microns, and the numbers YYY represent core diameter of the coil wire in microns (so P/N VMXY80-400-250 has a flexure 0.400mm thick, and a coil wound with 0.250mm wire).